

Installation, Operation and Maintenance Manual

ACO Grease Capture

General information

- The device is intended for the separation of grease and suspended solids from kitchen wastewater only.
- The device must be installed in compliance with all applicable local and national laws, and codes of practice including those relating to electrics and plumbing.
- Installation of the device should be performed by qualified technicians.
- The device must not be installed in any other way than as described in this Installation and Operation Manual.



Safety

- The ACO Grease Capture should only be connected to a properly grounded and waterproof power socket. Ensure the power socket is fitted with or supported by a dedicated ground fault circuit breaker/interrupter (GFCI).
- Connect the heater to the electrical supply after the unit is filled with water. This is achieved once water flows over the outlet weir.

2

The device must always be filled with water before turning on!

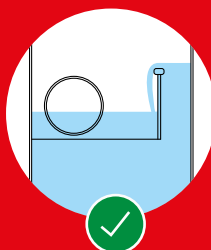
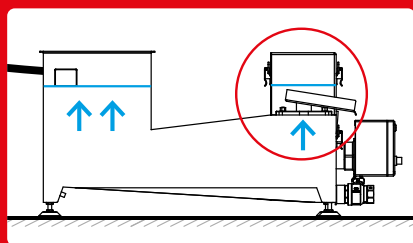

**Danger
of heating rod
damage!**

- If water needs to be drained from the device, the heater must be disconnected from the electrical supply first.
- Do not install the unit outdoors unless a waterproof cover is used.
- Do not remove the heater casing if it is connected to the electrical supply.

Process of installation

- An inlet and outlet pipe slope of at least 2%.
- Do not reduce the diameter of the outlet pipe.
- Piping before device inlet should be as short as possible
- Minimize the number of elbows on the outlet pipe.
- The device has an internal P-trap, there is no need to install a second P-trap at the outlet.
- Please check the device for damage before first use and report any missing or damaged parts to your local distributor.
- Do not connect the unit to a food grinder, potato peeler or waste disposal unit.
- Pipes leaving the outlet must be at least 2 inches in diameter.
- Remove any grease buildup or blockages from connecting drains before installing the ACO Grease Capture.
- The ACO Grease Capture is provided with an internal flow reducer to limit throughflow and to aid performance. Variable size flow reducers are available up to the maximum flow rate for a given separator size, depending on inlet pipe diameter.

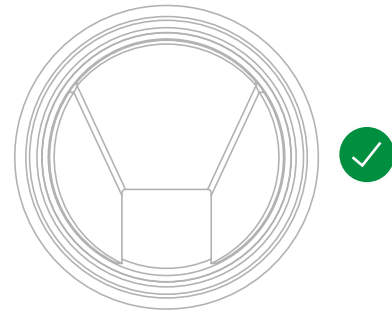

Reducer Art. No.	Max. Flowrate L/s
418029	0,5
418030	0,7
418031	1
418032	1,2
418033	1,5
418034	2,2

The flow rate of individual flow reducers is determined according to methodology established in the PDI standard.

Inlet and outlet connection

Ventilation pipes should always be open to atmosphere, either outside the building or by connection to an air admittance valve. Do not connect to sewage ventilation systems. Outlet ventilation protects against potential siphoning issues.

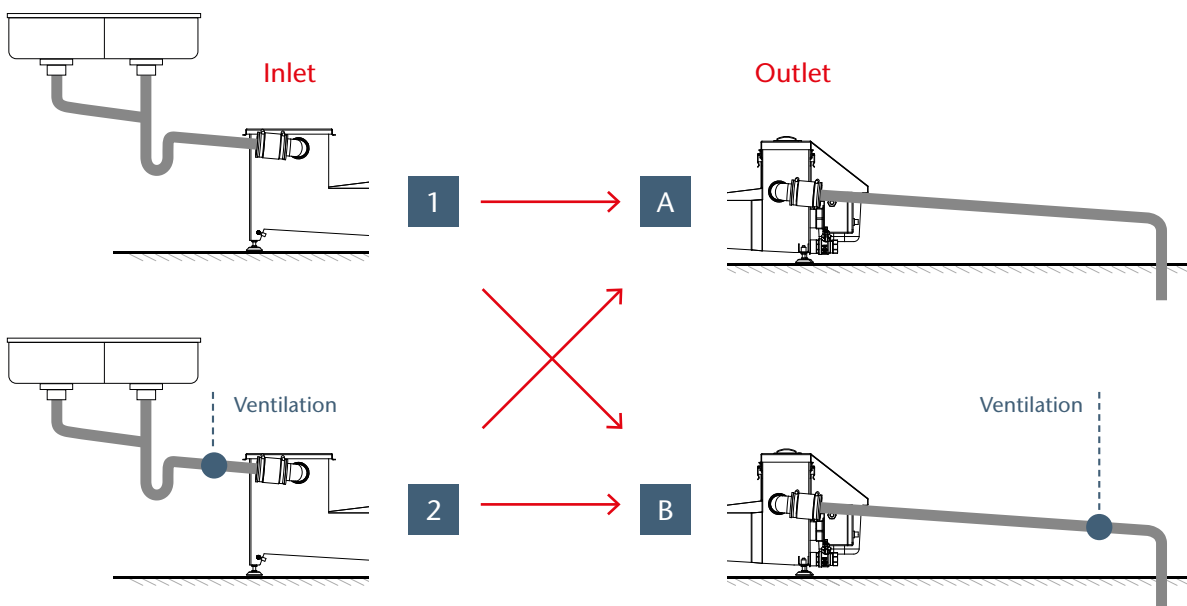

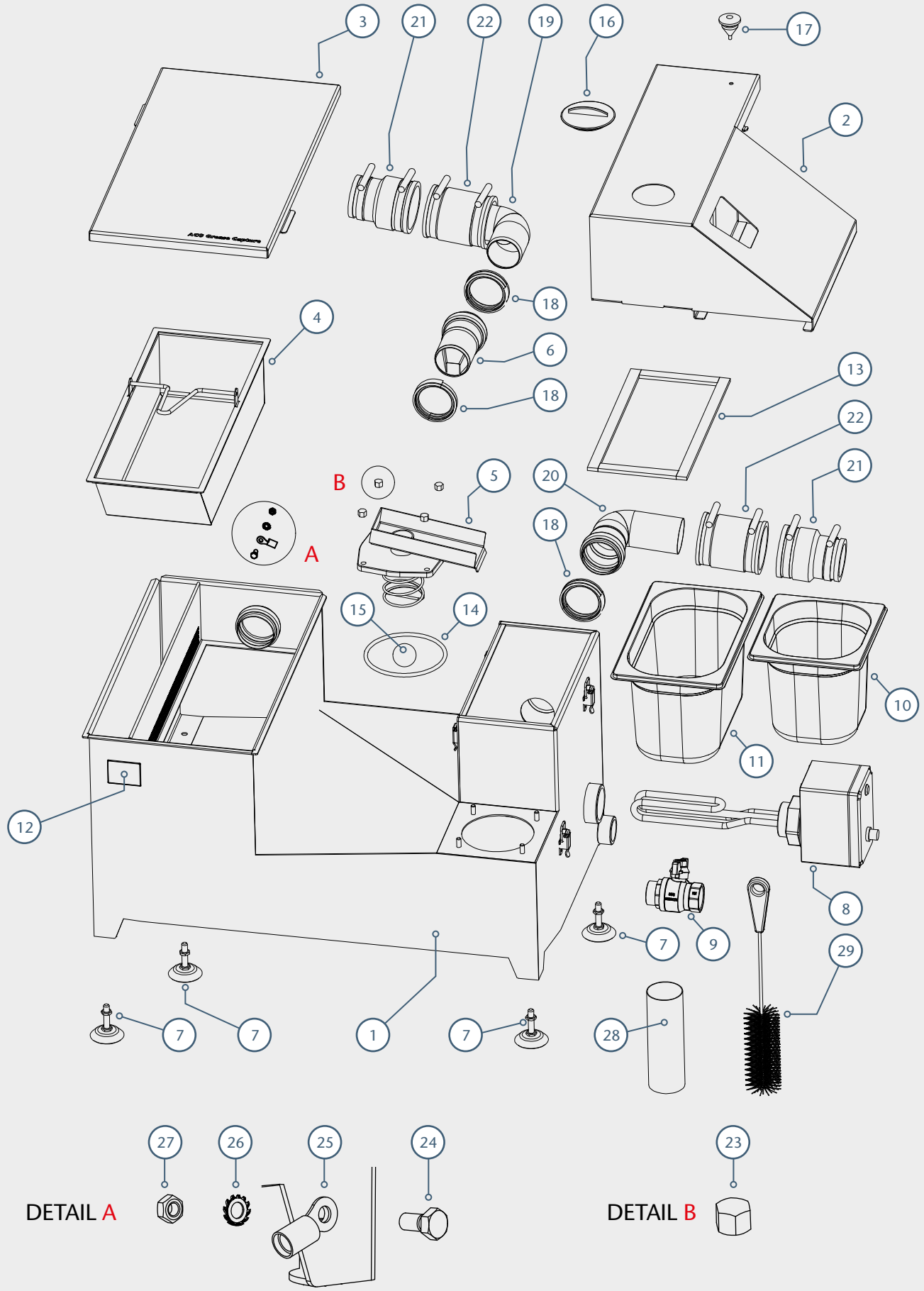

Component list

Item No.	Description	Total pcs	Article No. of 1 pcs			
			AGC 050	AGC 100	AGC 150	AGC 220
1	Welded container	1	E64656	E64084	E64675	E64702
2	Outlet cover	1	E64669	E64105	E64690	E64736
3	Inlet cover	1	E64663	E64104	E64689	E64710
4	Strainer basket	1	E64661	E64110	E64682	E64738
5	Oil valve	1		E64109		
6	Standard flow reducer	1		E65002		
7	Leveling foot with locknut	4		L16313		
8	Heater	1		Contact your dealer for specification		
9	Drain valve	1		M00676		
10	Gastro container 1/6	1	M01995		-	
11	Gastro container 1/4	1	-		M02186	
12	ACO logo	1		M02270		
13	Gasket	1		M02182		
14	O-ring	1		NM4348		
15	Ball	1		E65006		
16	Red cap	1		M02168		
17	Rubber plug	1		NM2542		
18	Pipe seal*	3		98400		
19	Inlet elbow*	1		L16533		
20	Outlet elbow*	1		L16532		
21	Rubber coupling 3" to 2"*	2		M01717		
22	Rubber coupling 2"*	2		M01718		
23	Blind nut	4		M02281		
24	Bolt	1		M02271		
25	Grounding eye	1		M02187		
26	Lock washer	1		M02272		
27	Nut	1		M02273		
28	Cleaning pipe	1		L16535		
29	Brush	1		M02021		

(*not required for every installation)

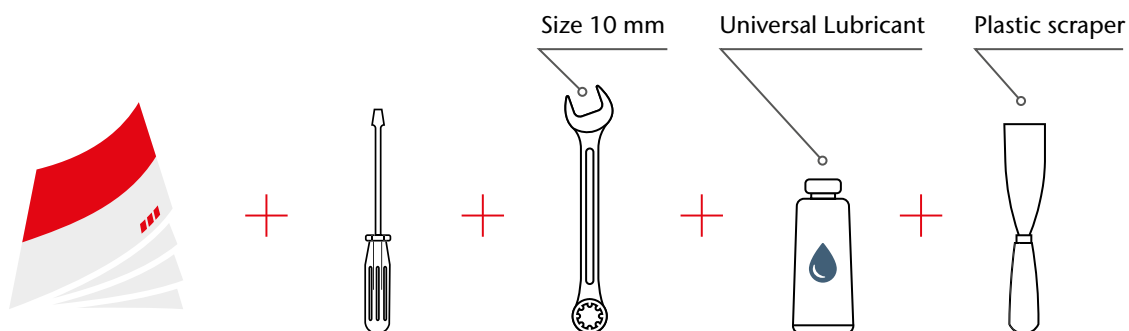

1

Installation

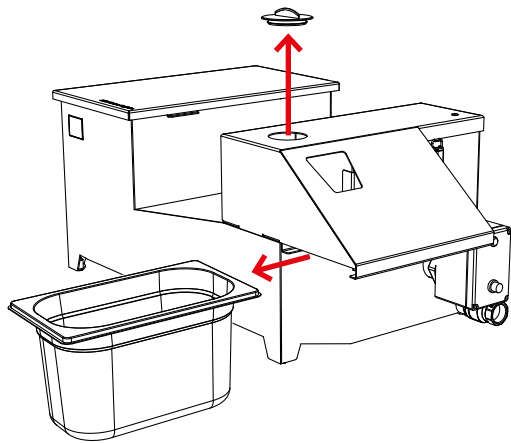

4x

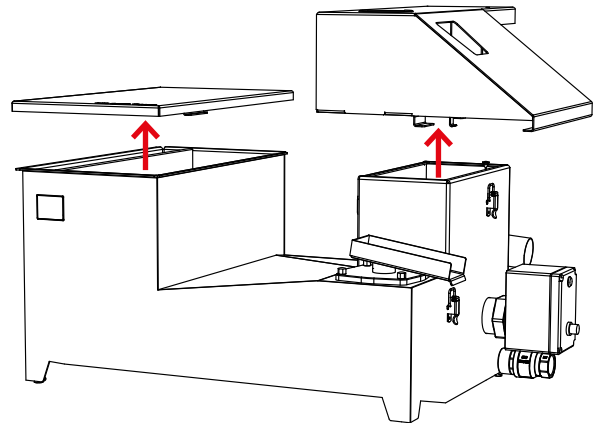
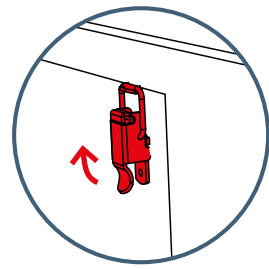

2

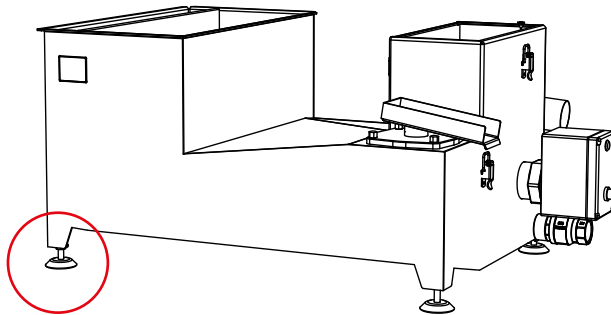

4x

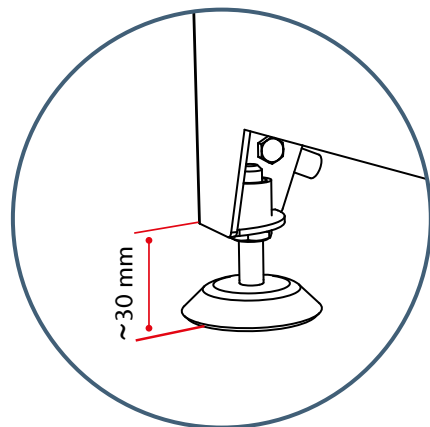
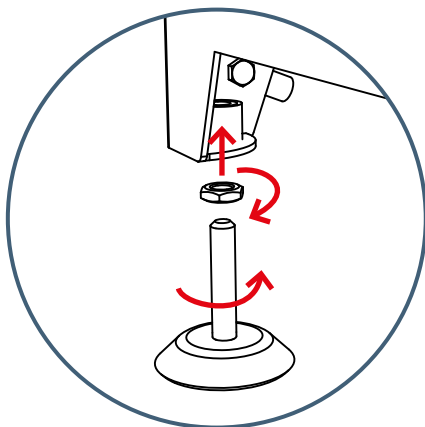

3

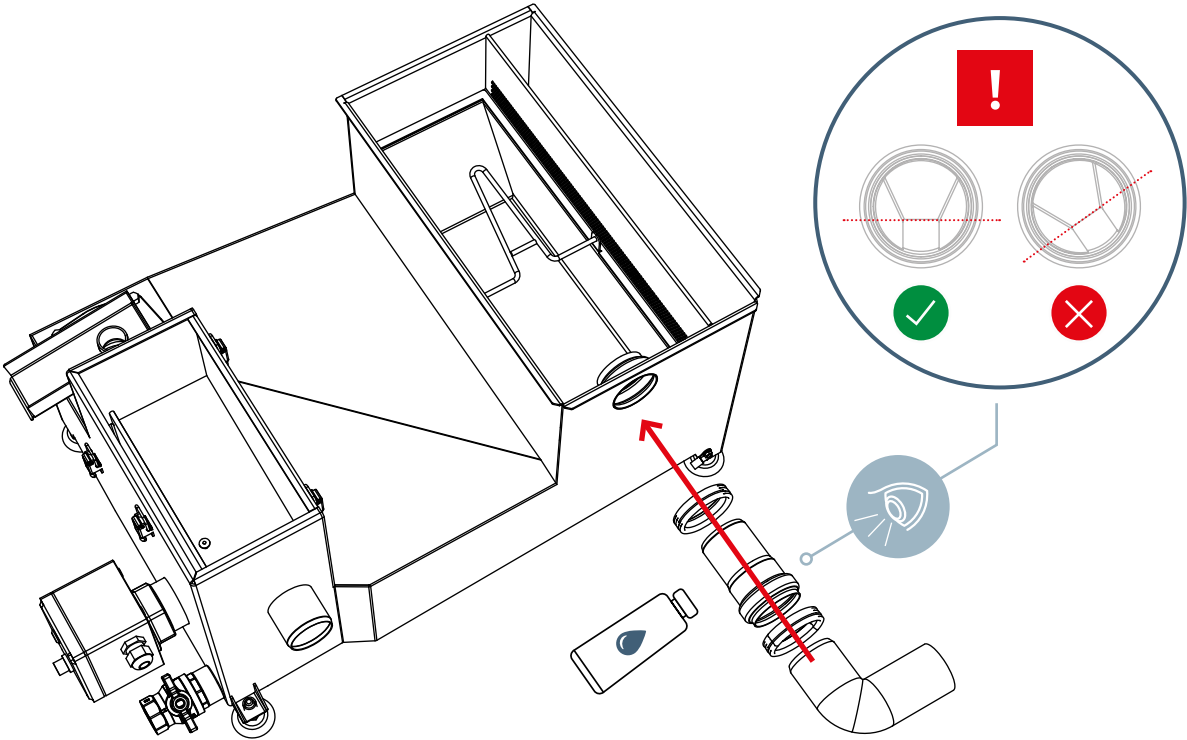

4

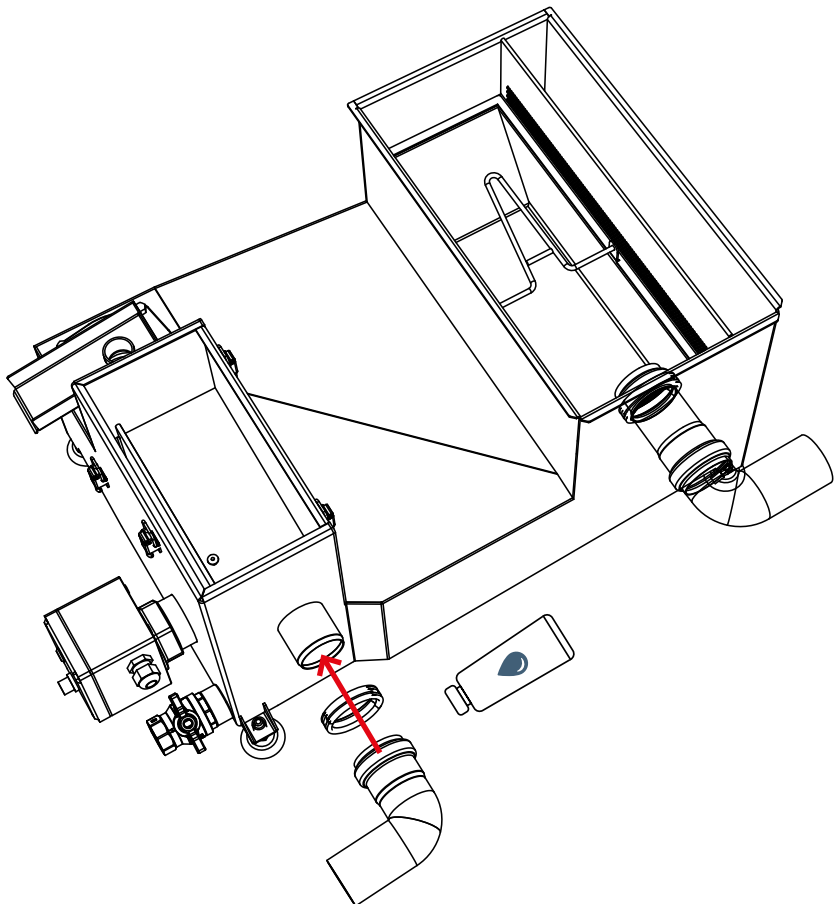

5

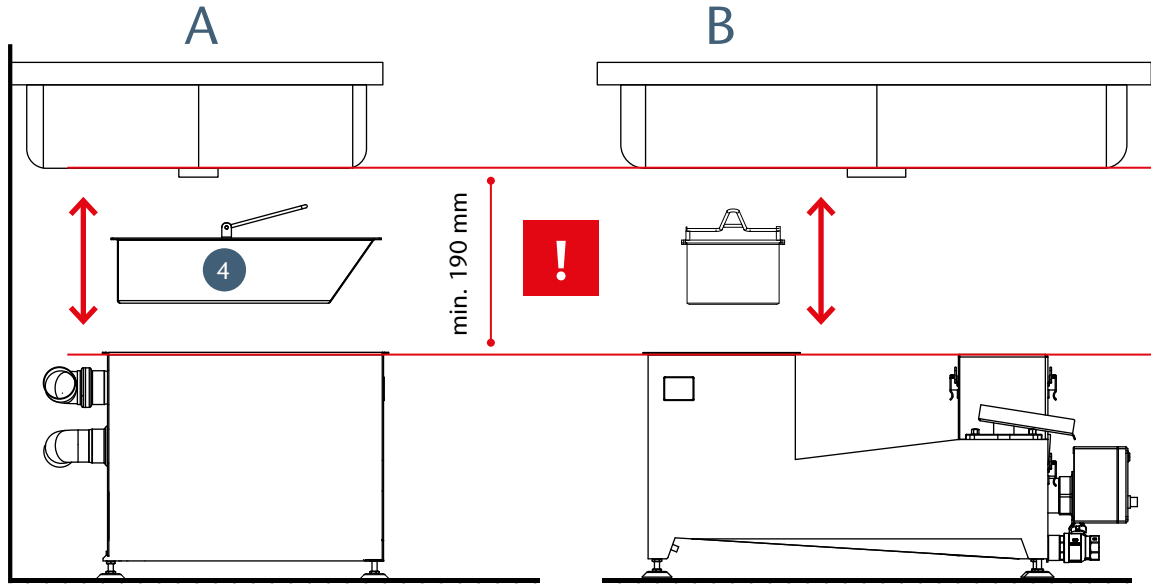
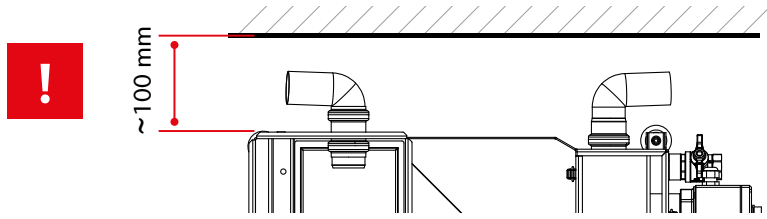

6

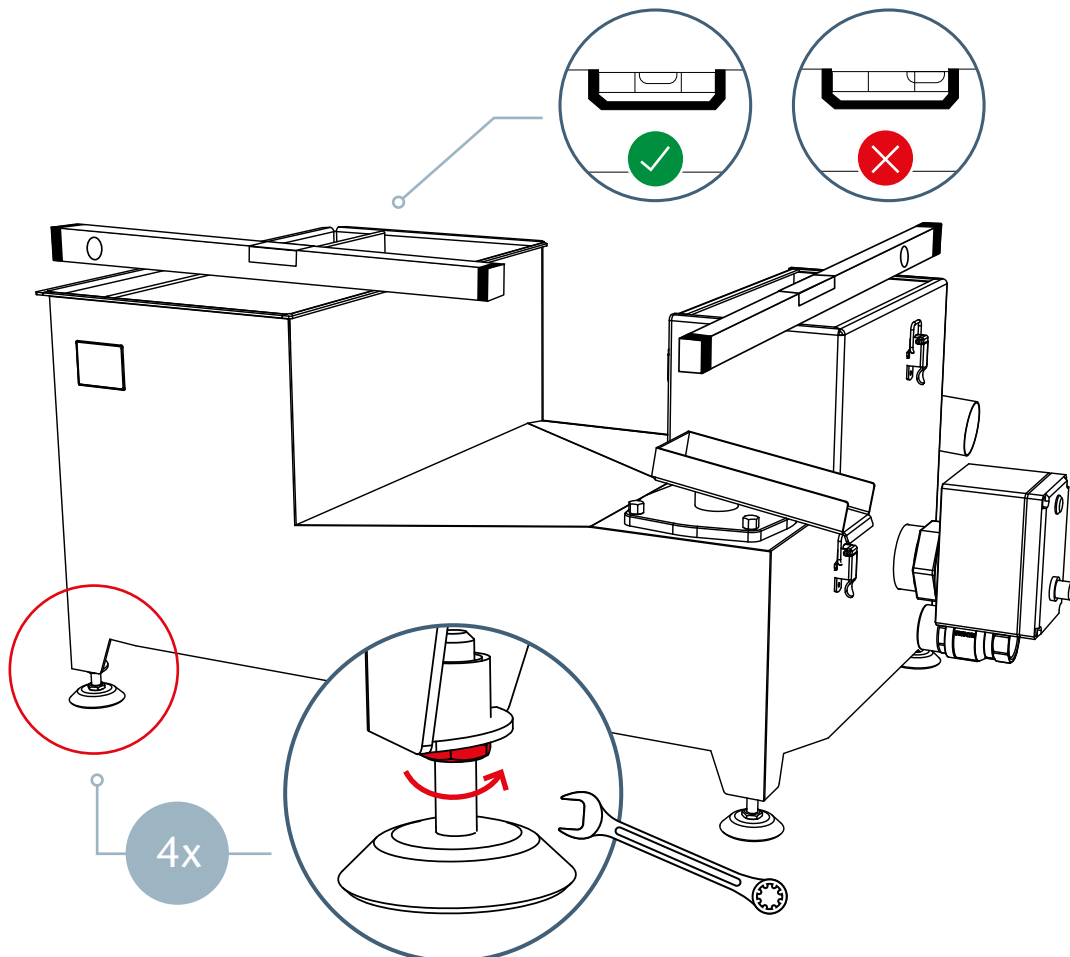

7

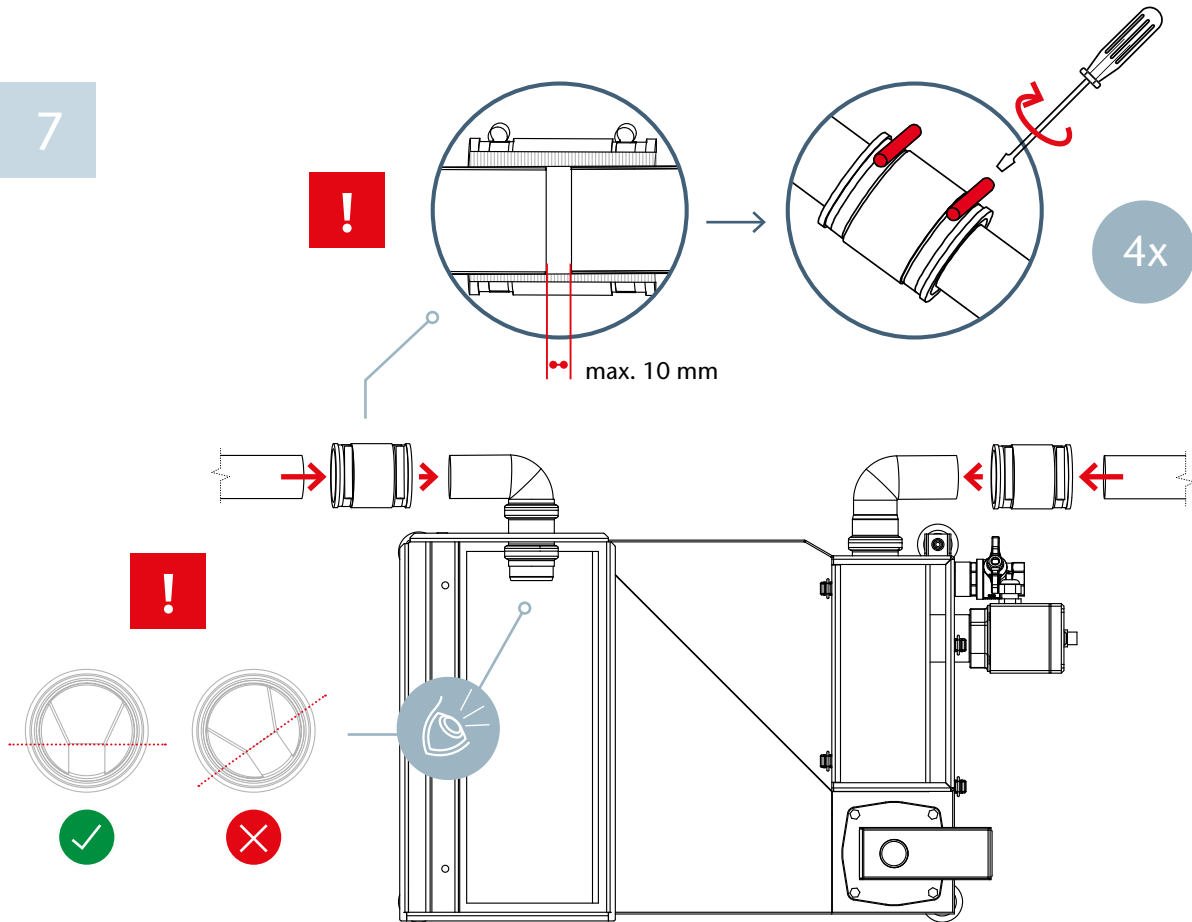

8

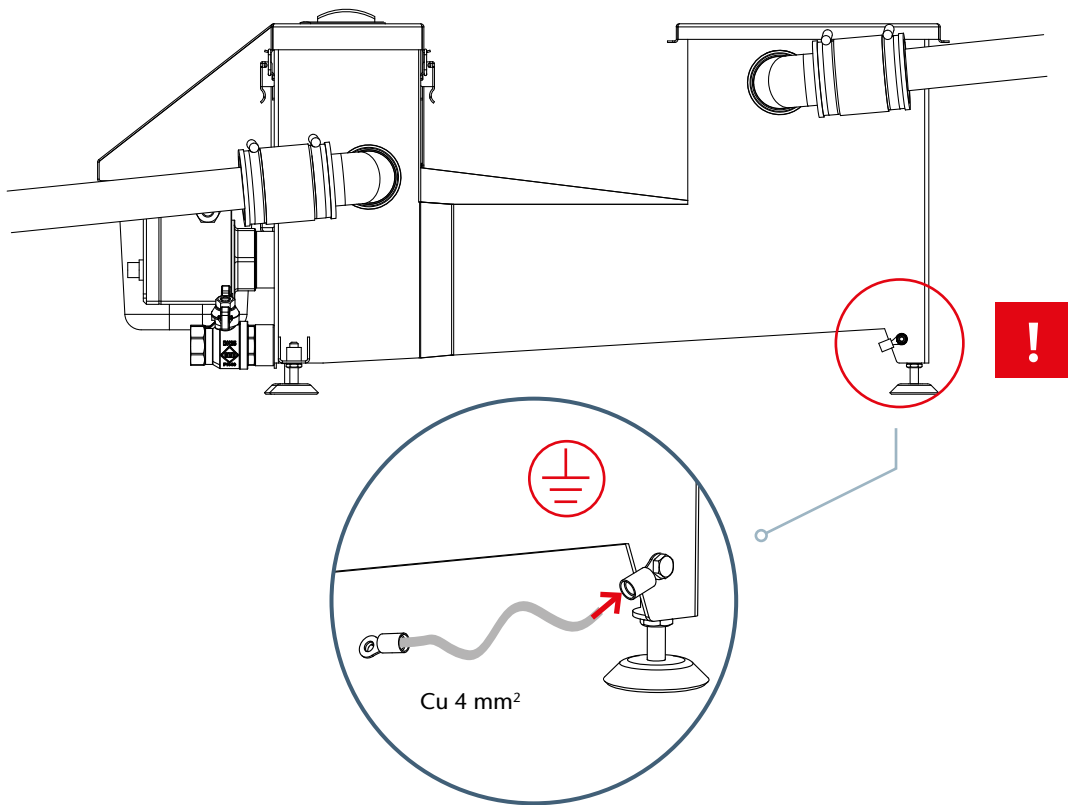

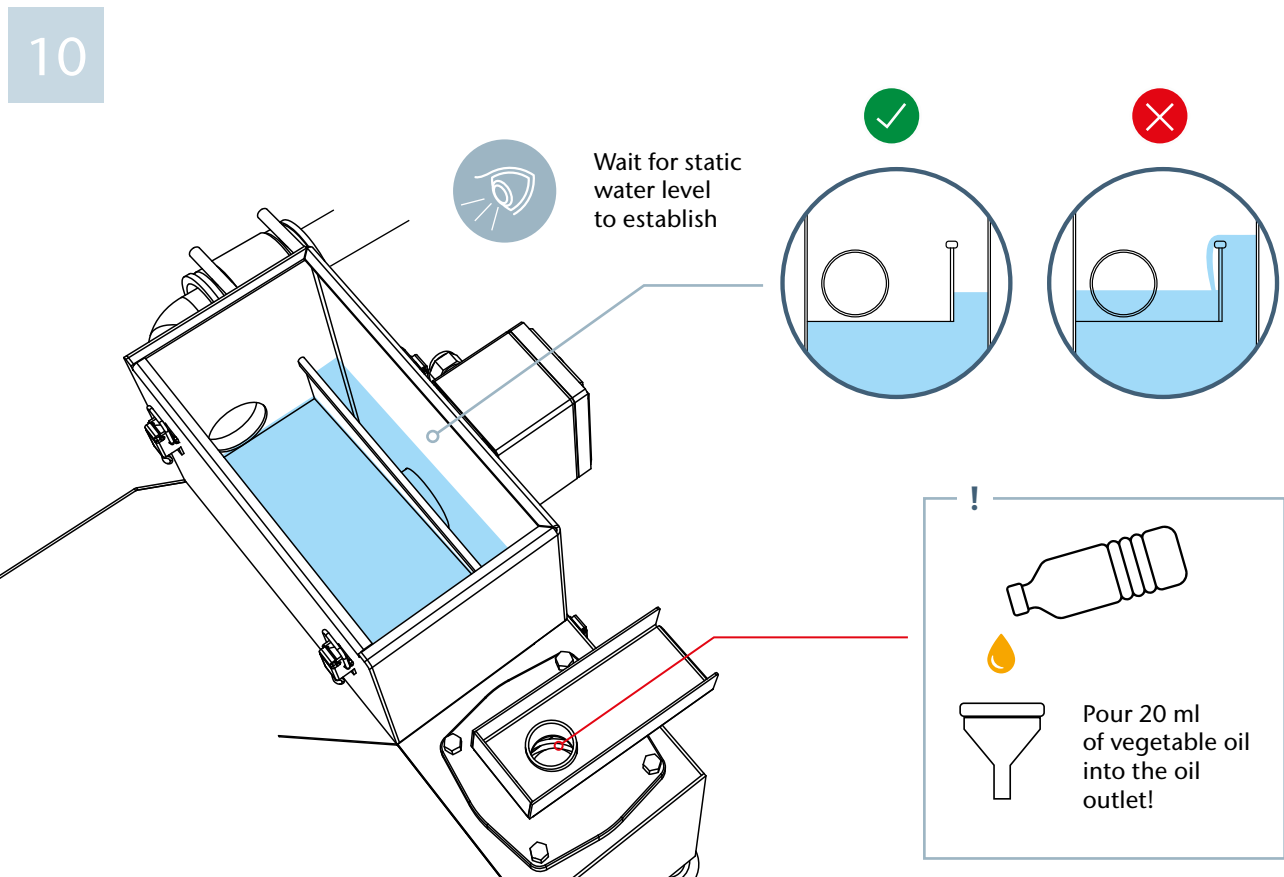
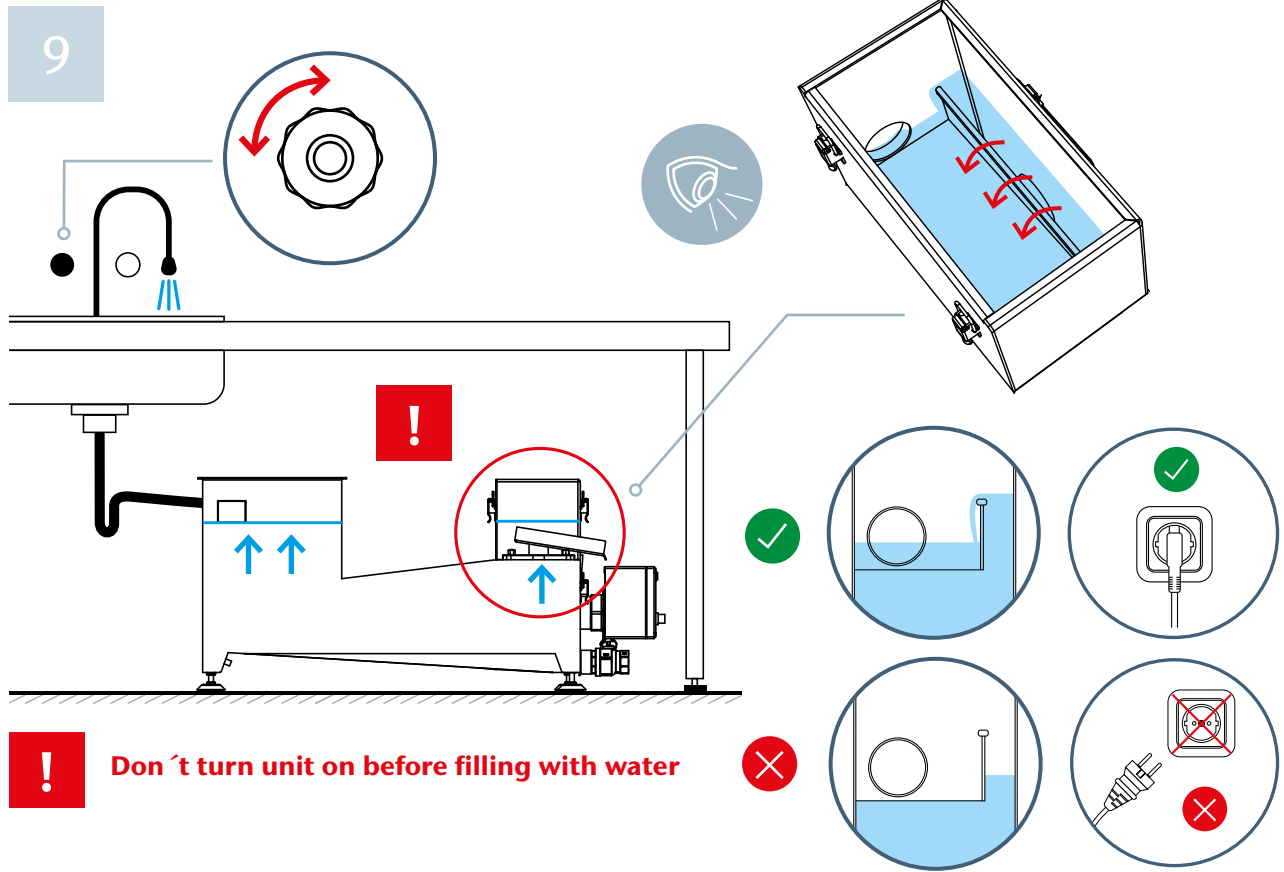

11

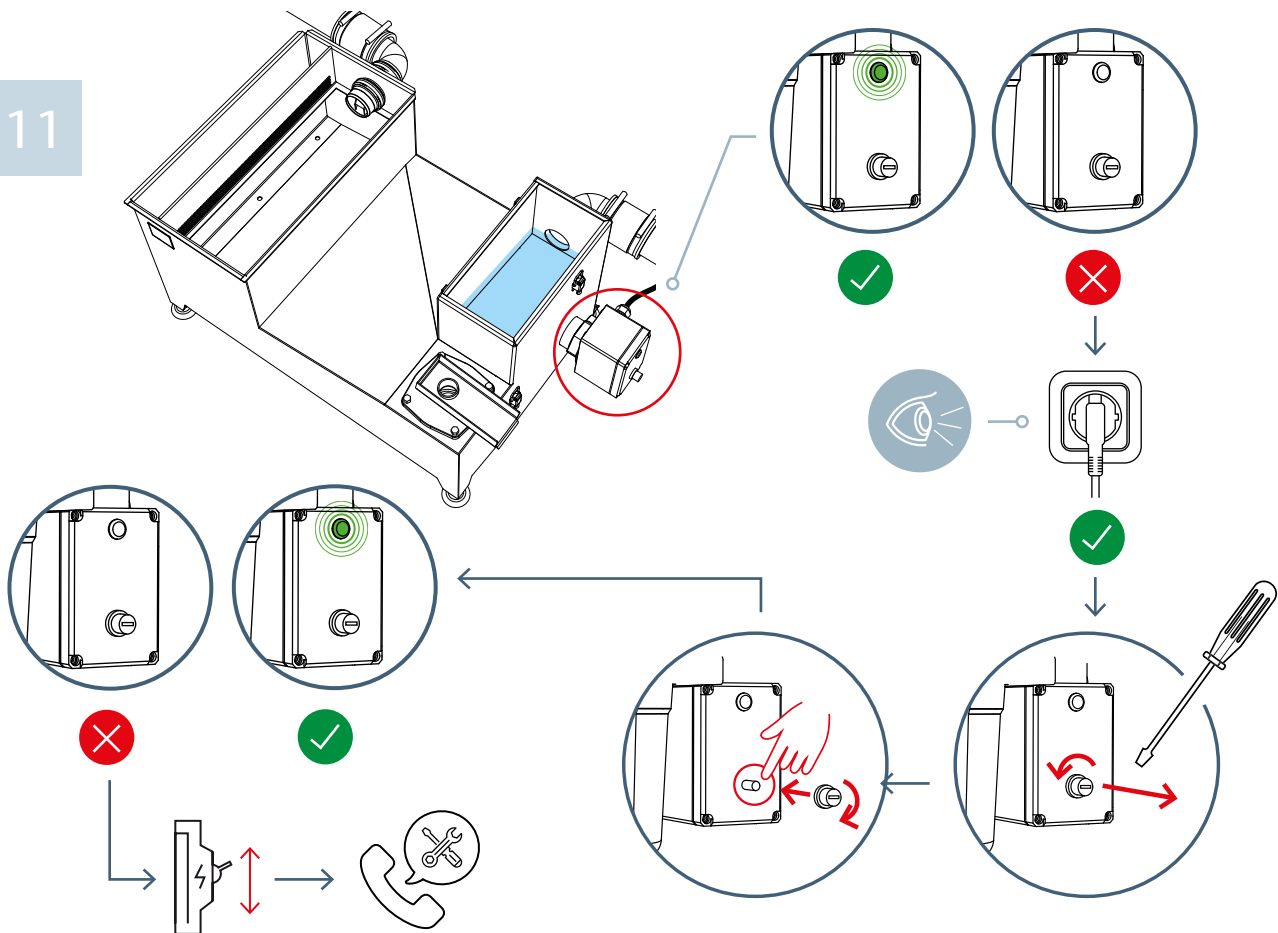

12

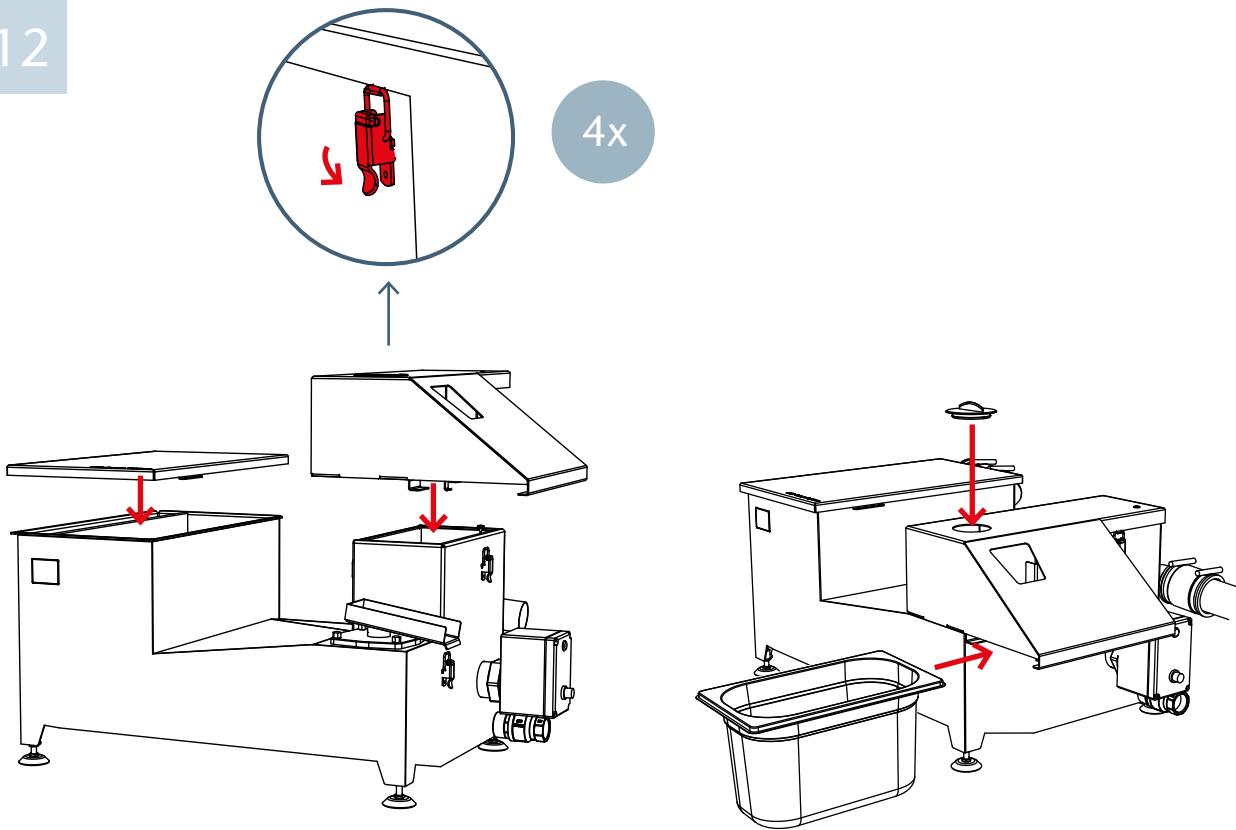

13

A

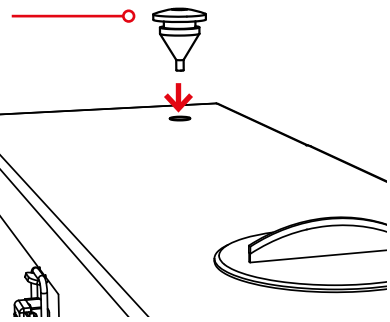
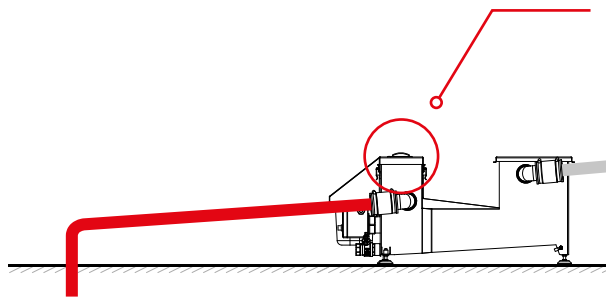

B

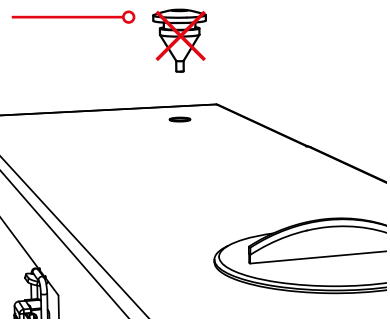
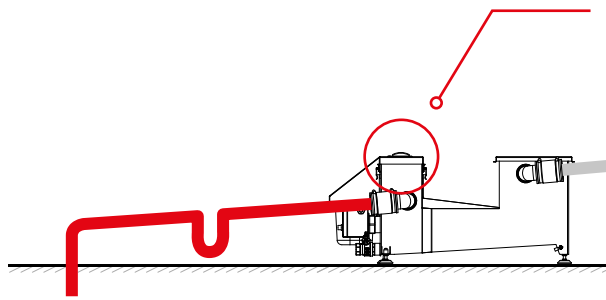

Operation

Conditions, restrictions and recommendations for unit operation (only for unit operation):

- If the unit has not been actively operating (no wastewater entering the unit) for more than two days, it is necessary to flush the unit with 30 litres of water each subsequent day.
- Never open the drain ball valve at the bottom of the separator during normal operation. This valve can only be opened during quarterly maintenance.
- **When the heater is plugged in, the unit must always be completely filled with water, otherwise the heater may suffer damage and require replacement.**
- We recommend that the drain downstream of the separator is cleaned once a year to prevent a reduction in the flow rate capacity of the unit and resultant overflows.
- The heater maintains the internal water temperature at around 40°C.
- When the heater is plugged in, the green light on the heater box must be on. If it doesn't light green, see page 17 Daily Maintenance OIM.

Maintenance

Conditions, restrictions and recommendations:

- The grease separation process loses efficiency if the unit is not properly maintained.
- The unit requires daily maintenance (this takes approximately five minutes). Maintenance is the responsibility of the operator. Weekly maintenance (takes around 10 minutes) is also undertaken by the operator's own staff. Quarterly service (1 hour) shall only be undertaken by a trained service person, please contact your local service provider to arrange.

1 Daily Maintenance

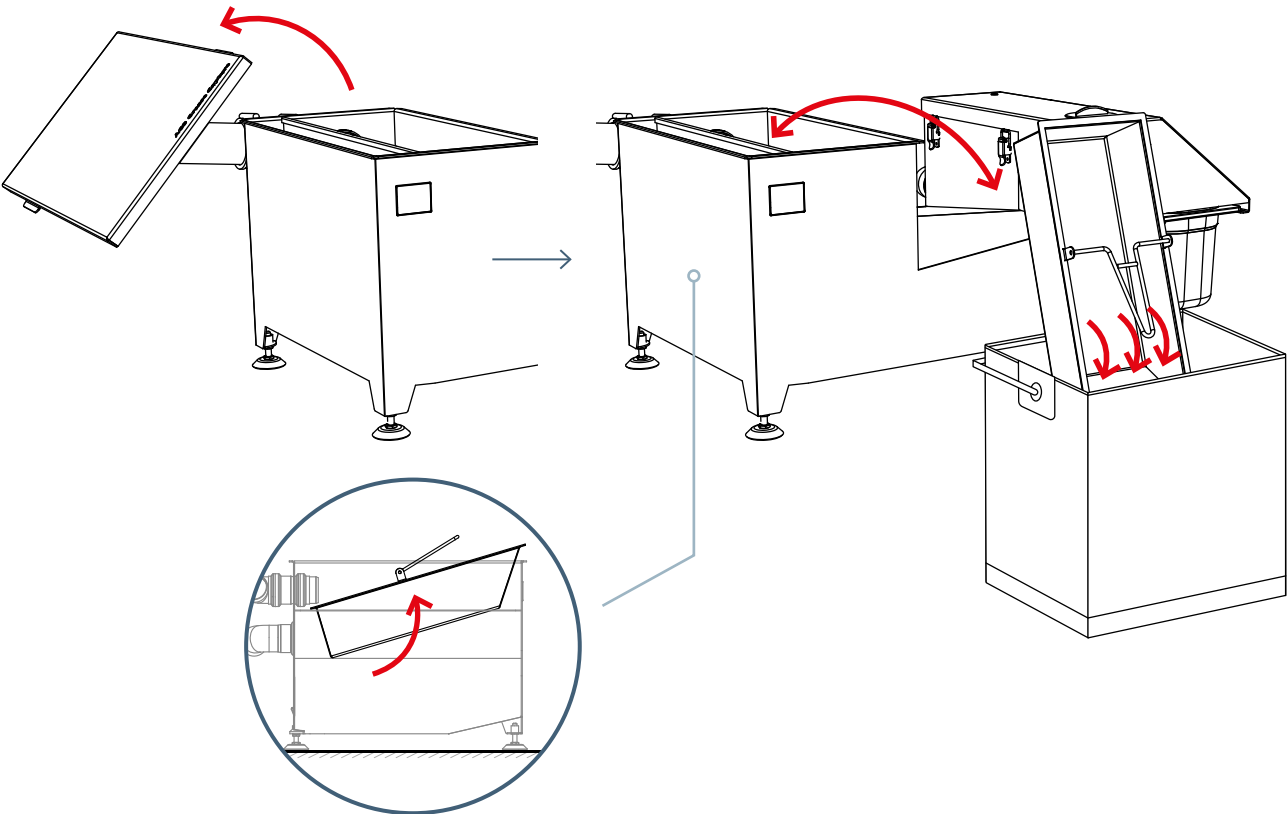

2

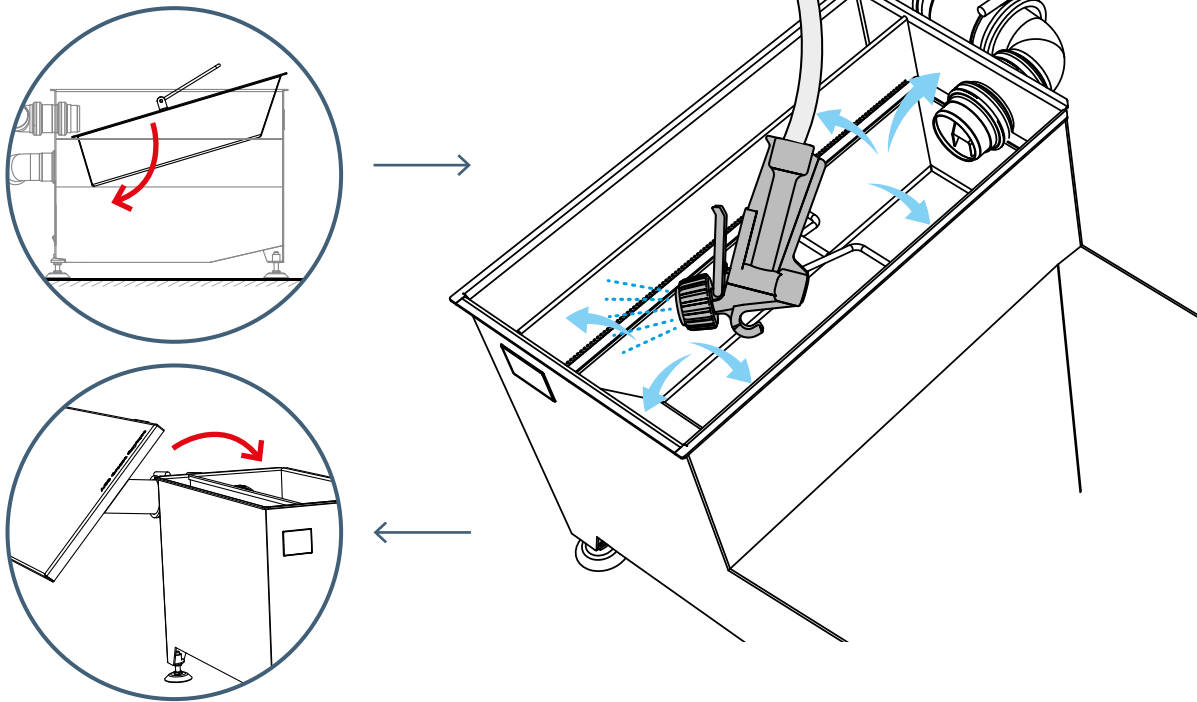

3

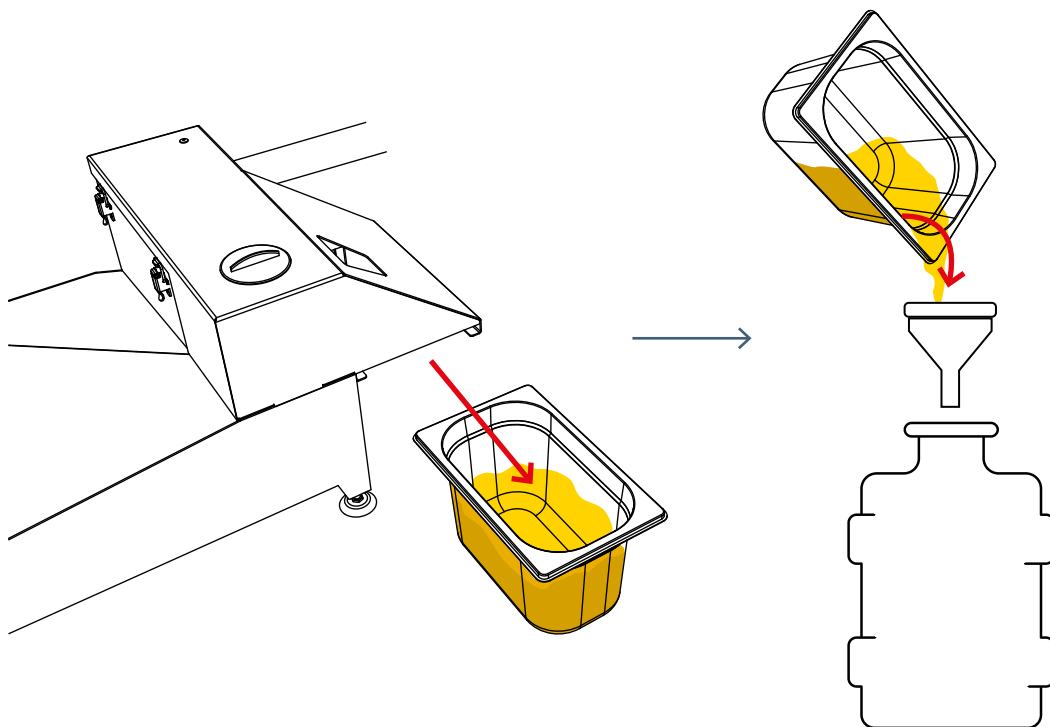

4

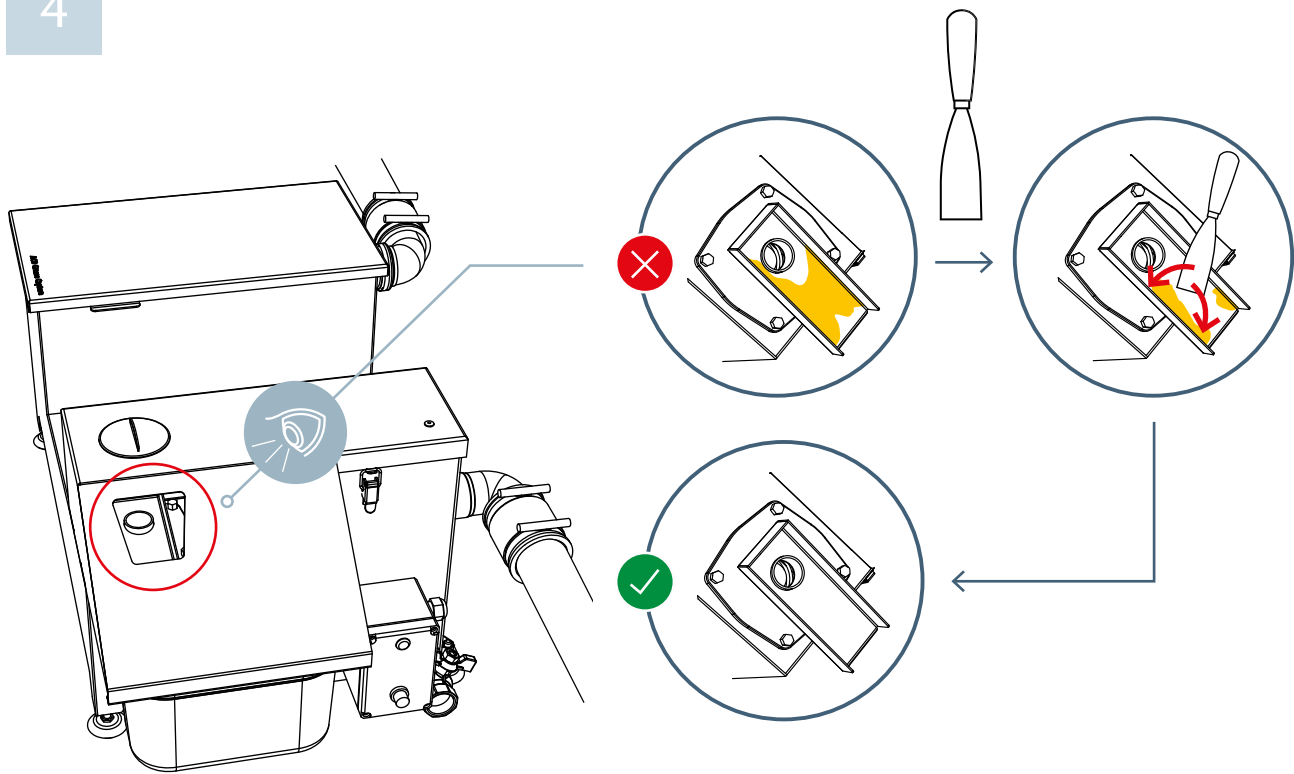

1

Weekly Maintenance

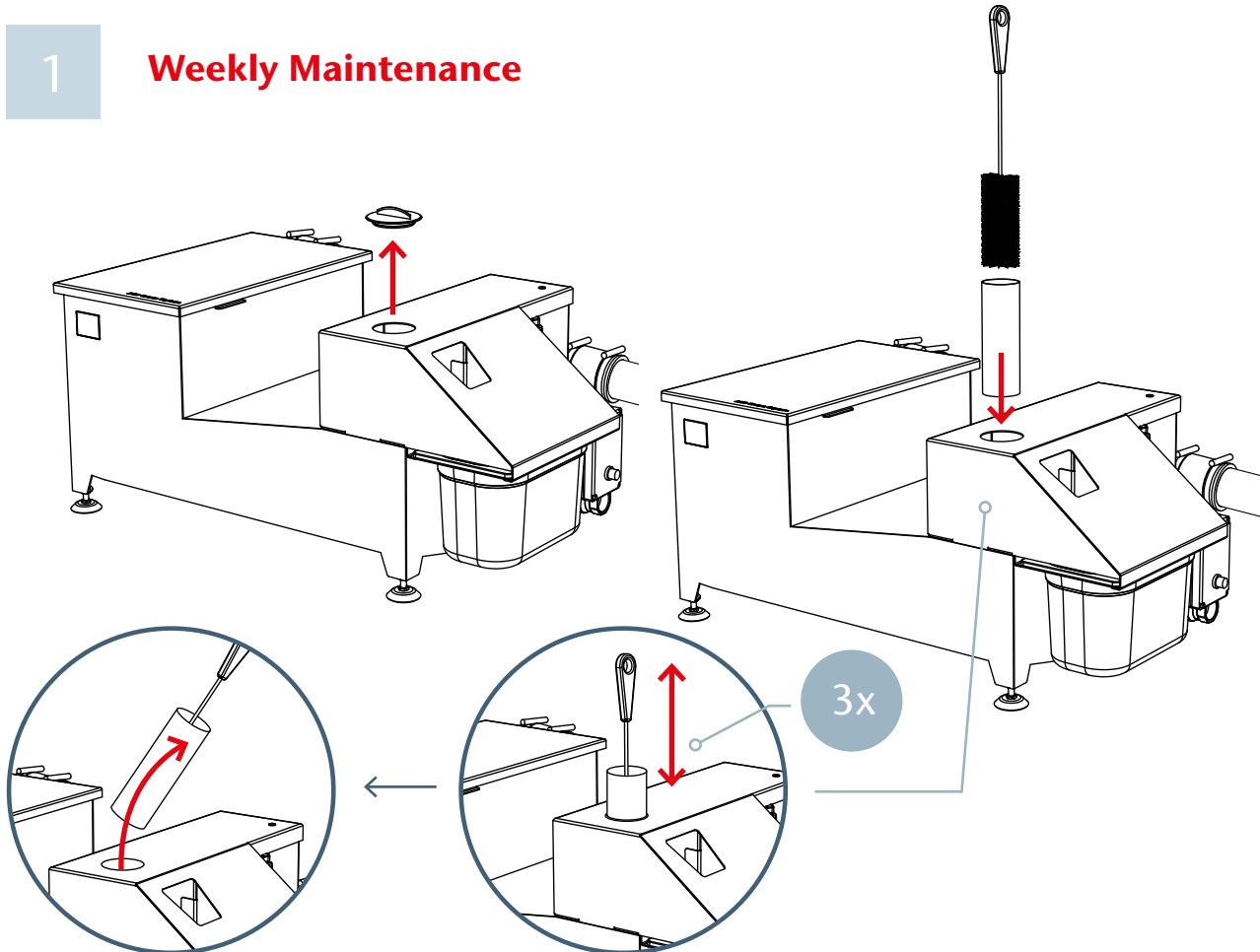

2

4x

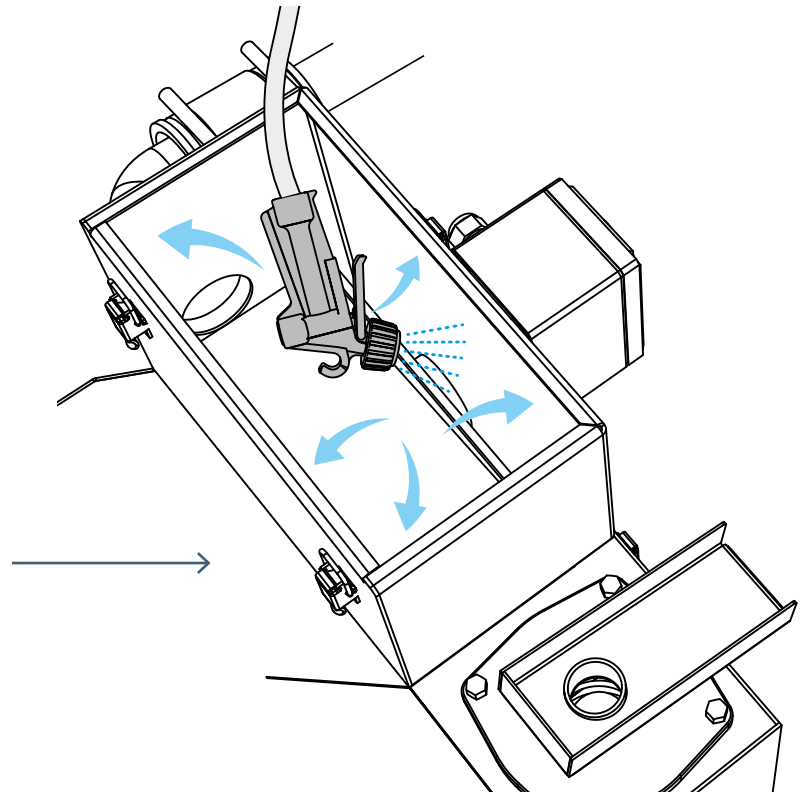
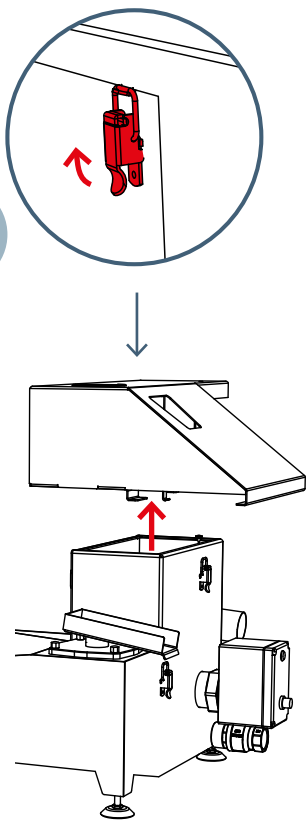

3

4x

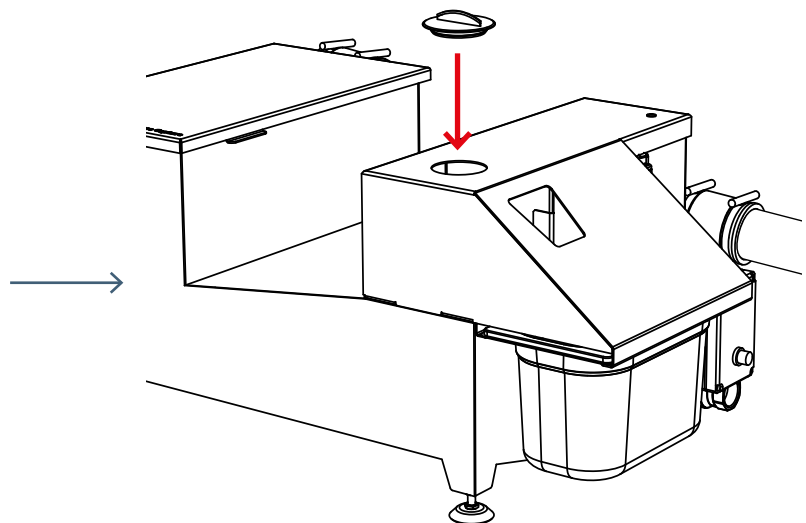
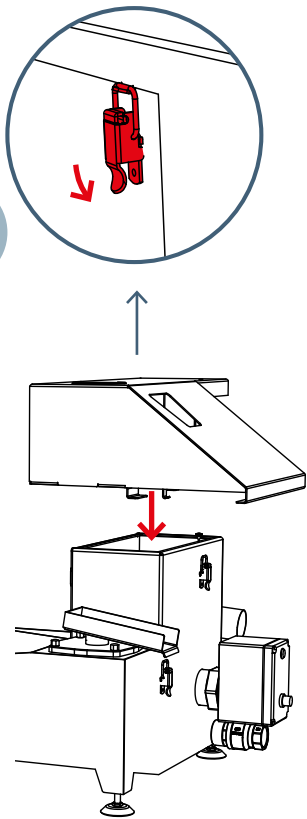

4

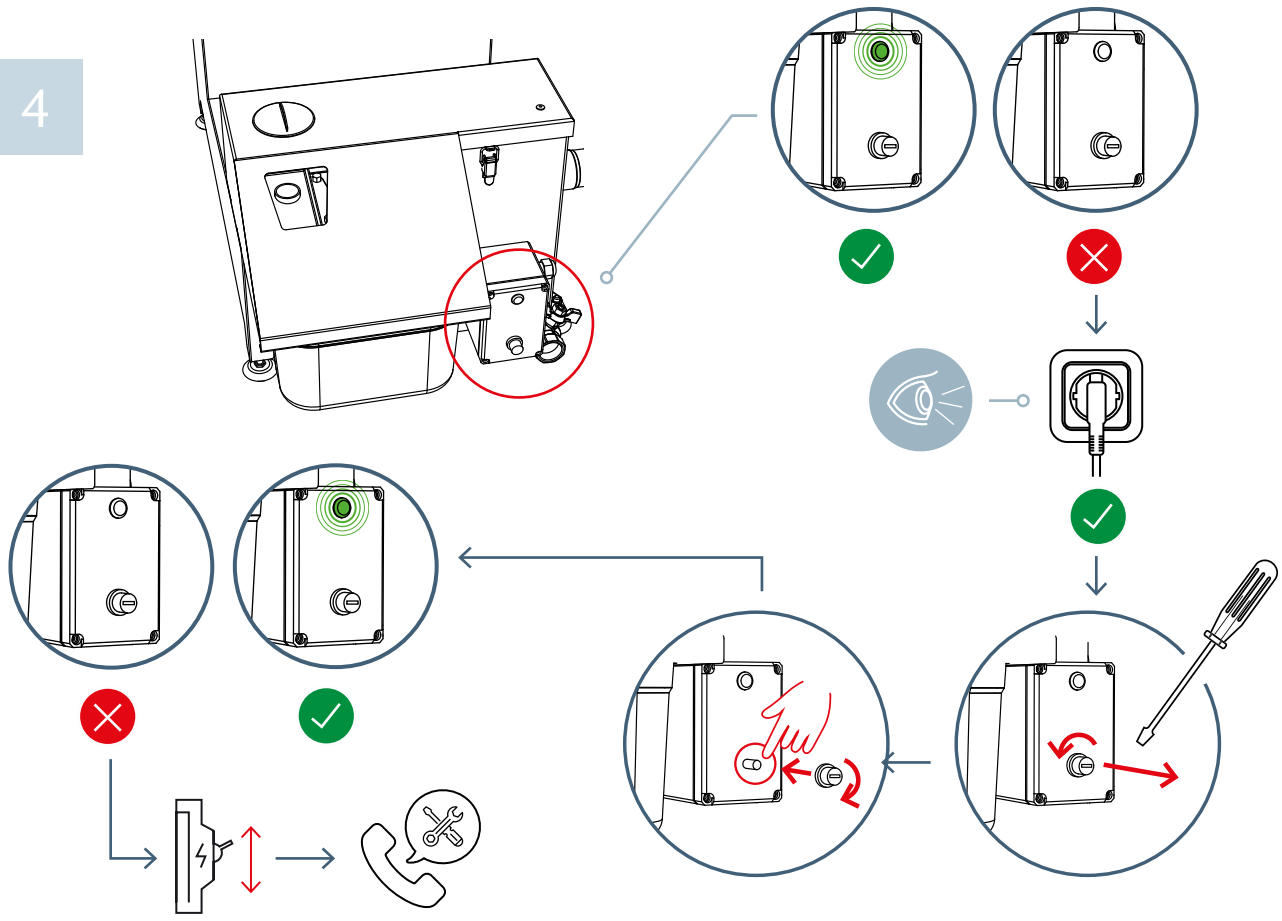

1

Quarterly maintenance (done by approved service partner)

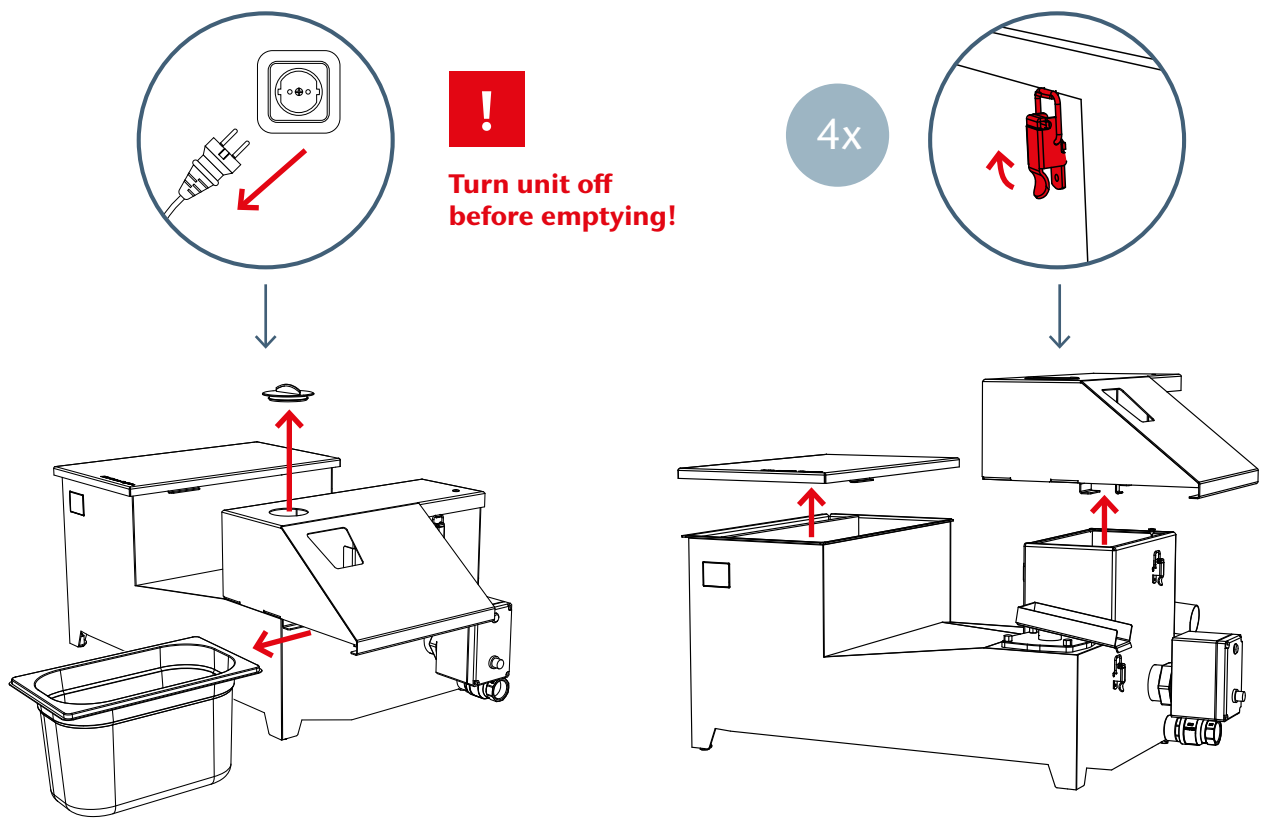

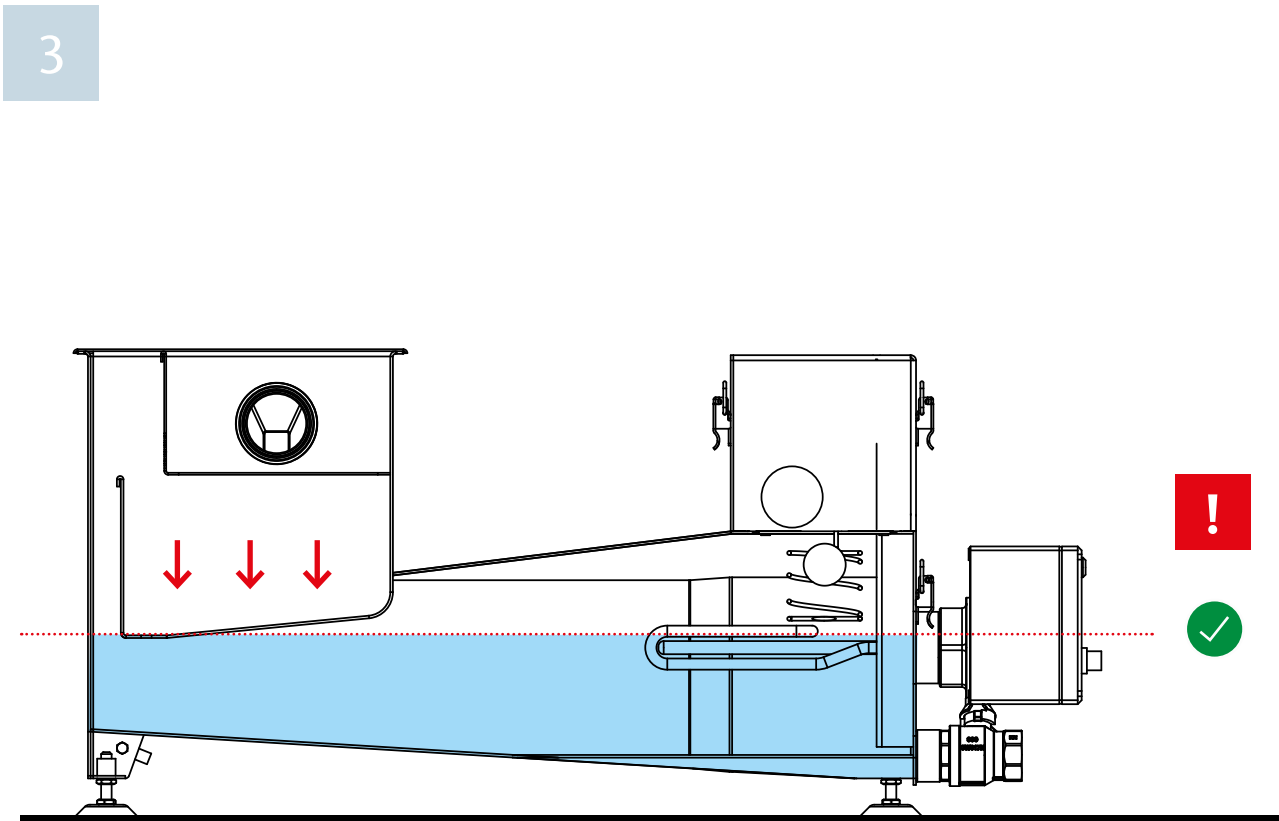
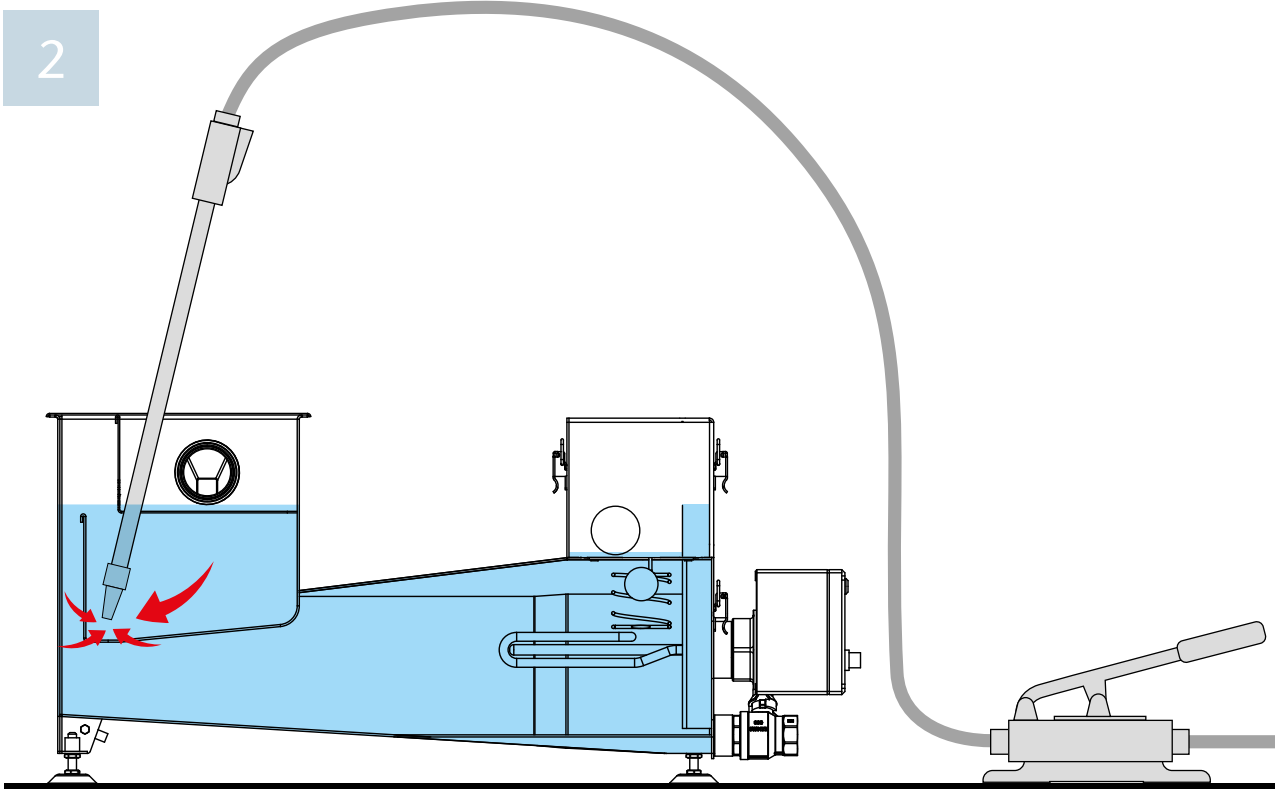

4

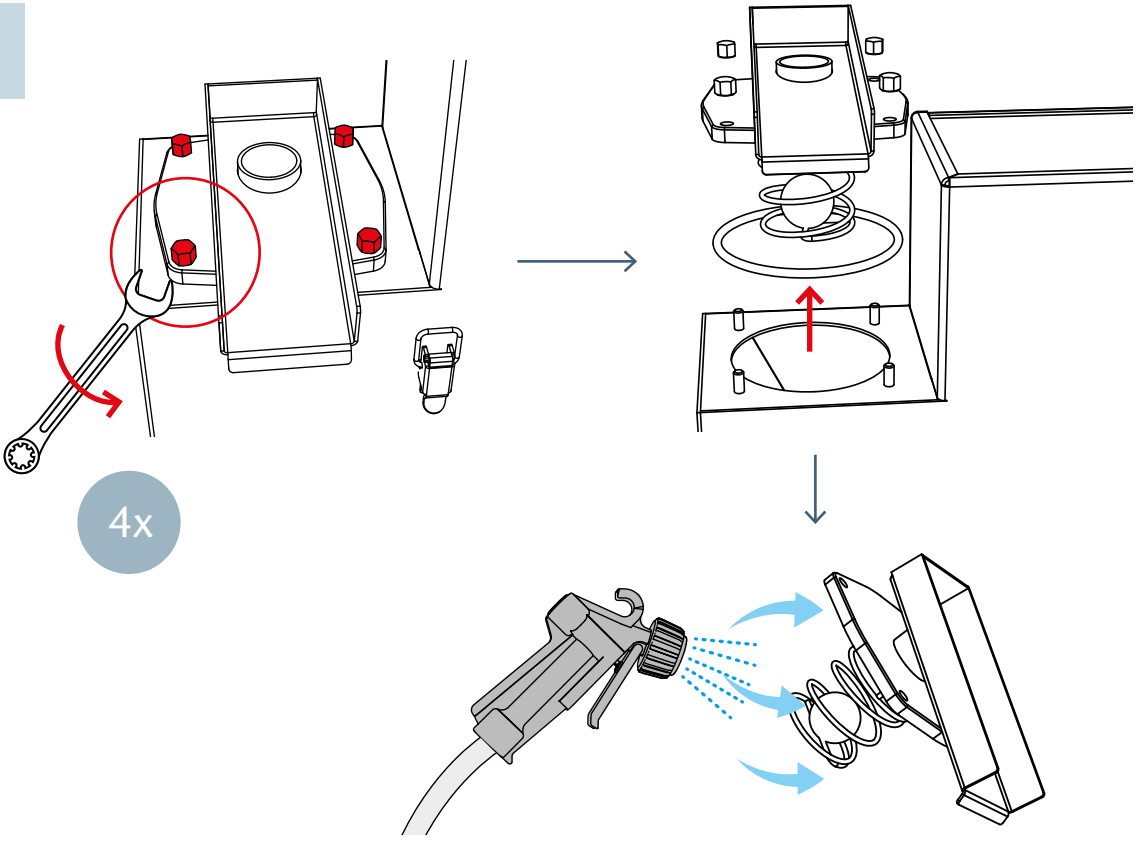

5

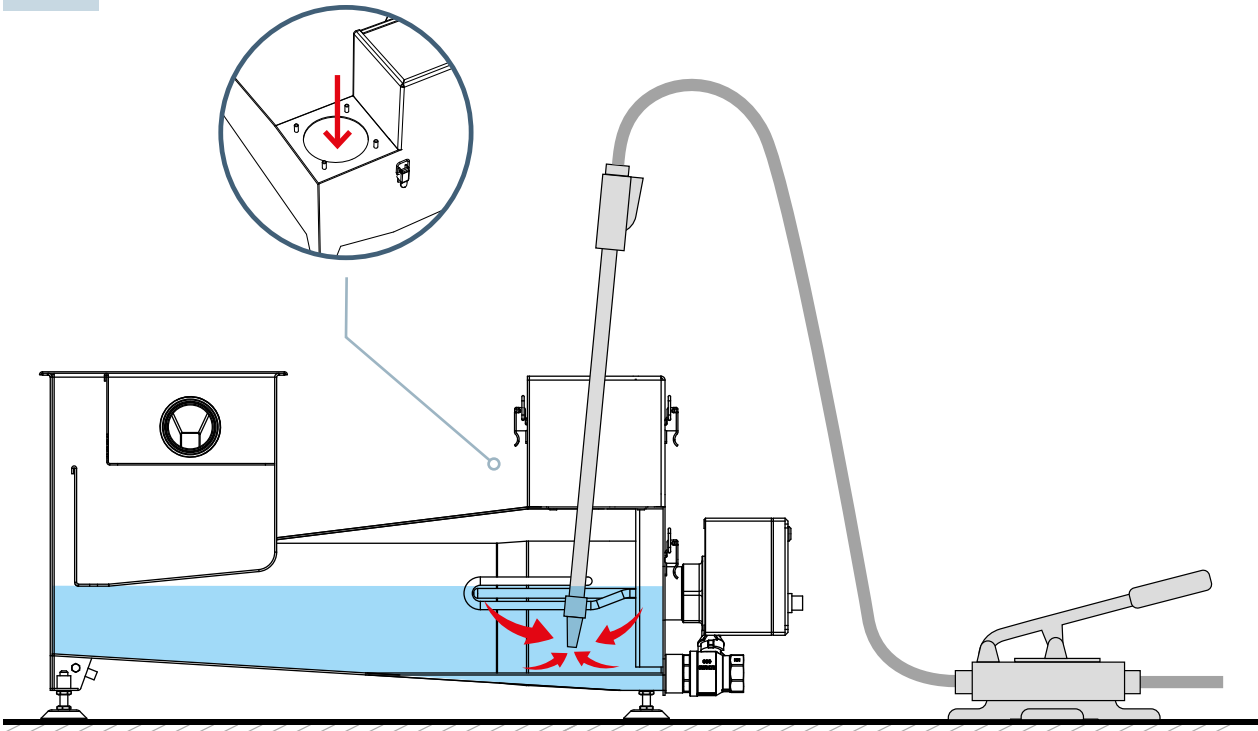

6

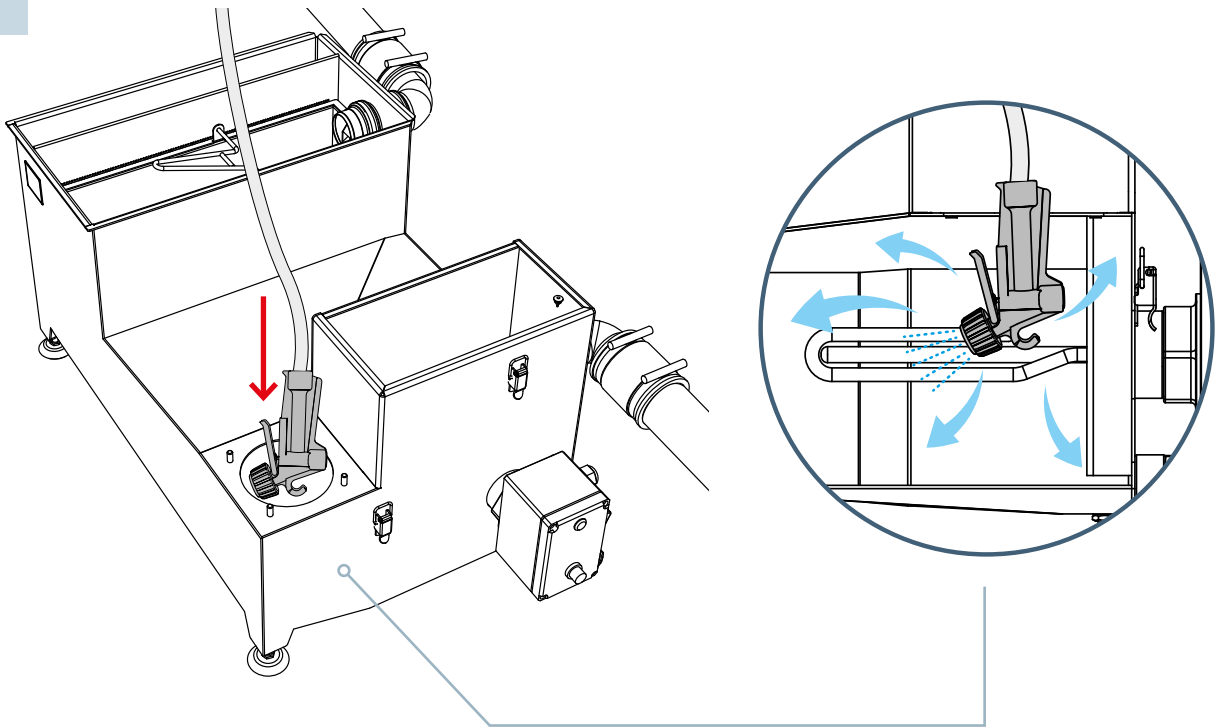

7

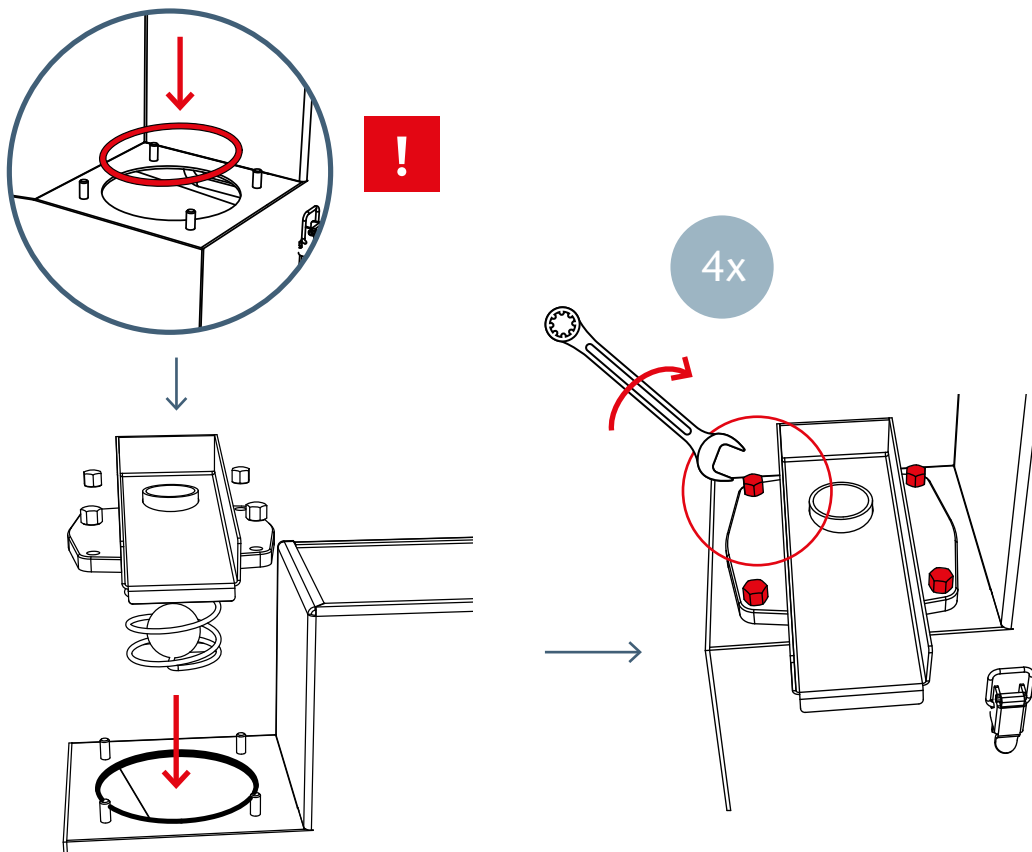

8

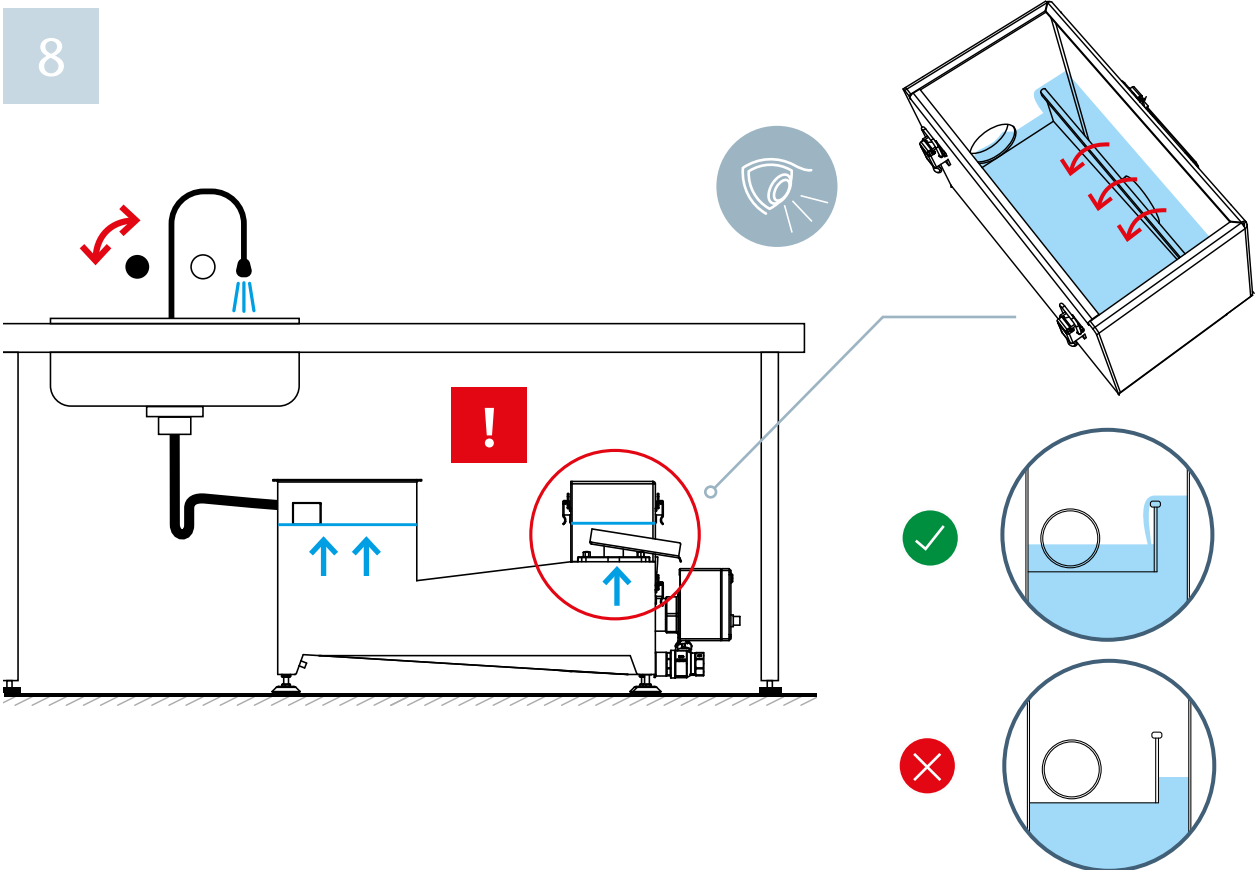

9

! Don't turn unit on before filling with water

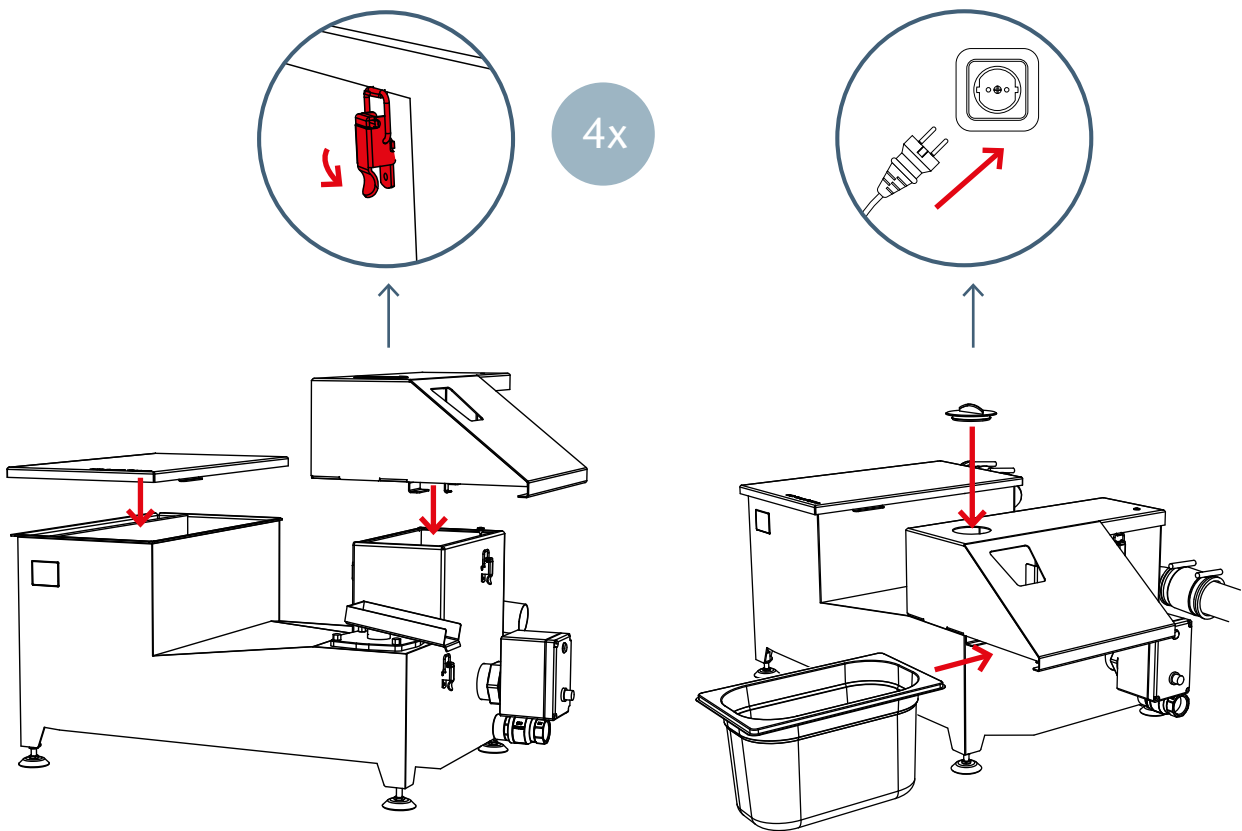

Troubleshooting

Problem	Cause	Solution
Odour	Irregular wastewater inflow, downtime more than two days.	Should operational shutdown last longer than two days, flush the separator with 30 litres of water from the sink daily.
	The rubber plug (item 17 page 4 IOM) is removed because a P-trap is installed after the separator.	Remove the P-trap and return the rubber plug to the drain hole. The separator has an internal P-trap, no external P-trap is required on the outlet pipe
	The inlet chamber is not maintained.	Remove the inlet chamber cover and use the spray head to remove deposits on the walls. Do not remove the basket from the chamber during cleaning.
	Oil leaked to the oil valve (pos.5 page 4 IOM).	Clean grease residue from the oil container.
	Decomposing grease residue in the oil container.	Clean grease residue from the oil container.
The oil valve slip is clogged with solidified grease	The heater does not heat.	Check if the green light on the heater is on. If not, check the plug, the heater thermostat reset button and the circuit breaker in the electrical switchboard.
	The heating element is coated with sludge, heating itself but not the fat.	Touch the upper sloping plate of the separation chamber. If operating correctly, the plate should be hot to the touch. If the plate is not hot then the heater is coated with sludge and more thorough maintenance is required, see page 17 - Quarterly maintenance IOM.
Separated grease does not flow into the oil container.	Clogged oil valve. Plastic ball stuck to the oil valve seat.	Clean the oil valve with a brush - refer to page 15 - Weekly maintenance IOM. Shorten the oil valve cleaning interval from weekly to daily.
	There is only an emulsion or fat free wastewater flowing into the separator.	-
Water flows into the oil container.	Oil valve seat or plastic ball is clogged with debris.	Clean the oil valve with a brush - refer to page 15 - Weekly maintenance IOM.
Waste water flows from the separator	The inlet chamber basket is full of food waste, stopping water entering the separator.	Empty the basket and consider shortening the emptying interval to twice daily.
	The drain pipe downstream of the separator is partially or completely blocked.	Clean the drain pipe. Eliminate the cause of the pipe blockage.
	A small diameter drain pipe is used downstream of the separator and is not able to handle peak inlet flow.	Replace the inlet reducer with a smaller one to reduce the maximum flow rate of the separator.
Clogged inlet flow reducer	Bigger pieces of food debris pass through the sink into the separator.	Install a plughole strainer. Open the inlet chamber lid and remove any material from the clogged reducer.

ACO. creating
the future of drainage

